

# APPLIQUE LACING

## RECOMMENDED USAGE:

Decorative stitch on belts, purses, wallets, etc. Can also be used to overlay one piece of leather on another, such as a tooled initial patch on a purse.

Use 3/32", 1/8" or 3/16" lace with correspondingly sized holes or slits.

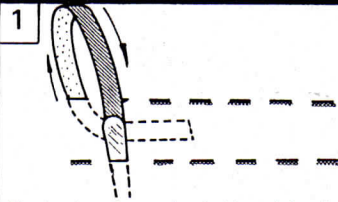

Beginning from backside of leather, pull needle and lace through first slit in top row. Leave about 3/4" of lacing end in slit, then push needle and lace through second slit on bottom row. Pull stitch snug but not tight.

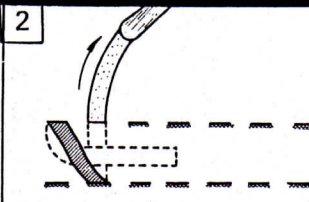

Lace up through second slit in top row, latching lacing end under stitch on back of leather.

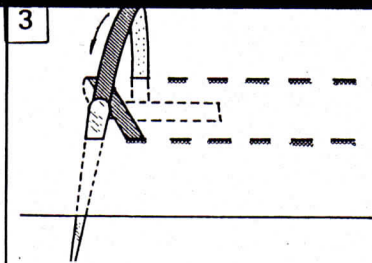

Cross over first stitch and lace through first slit on bottom row. This will form a cross or "bight".

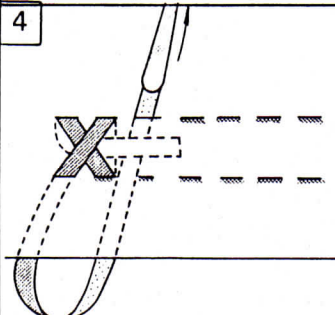

Lace up through third slit on top again catching lacing end under stitch on back of leather.

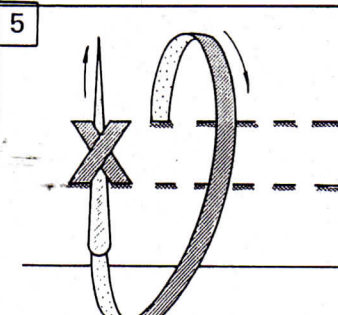

Push needle under cross or bight as shown.

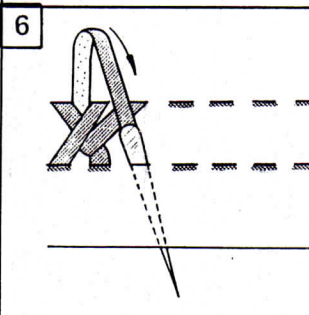

Pull stitch under bight snug but not tight. Lace through next slit in bottom row.

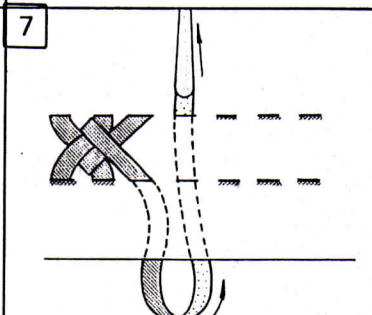

Lace up through next slit in top row, (second bight formed). Lace under second bight as in step 5.

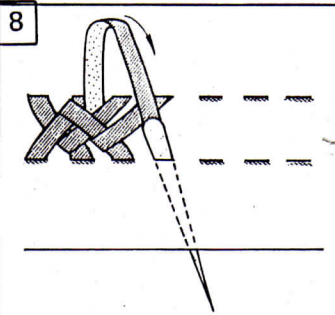

Lace through next slit in bottom. Continue lacing following the same procedures as in steps 4, 5, and 6.

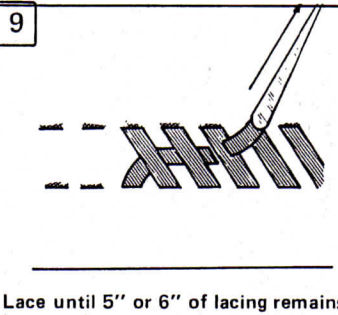

Lace until 5" or 6" of lacing remains. Lace under two stitches on the backside of leather and trim off excess. You are now ready to splice in a new length of lace.

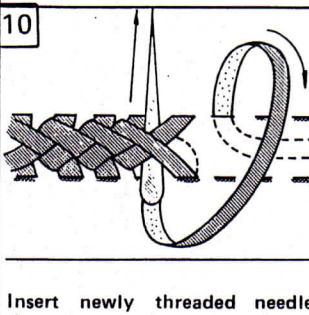

Insert newly threaded needle up through next slit in top row, leaving 3/4" of lacing end in slit. Push needle up through bight as shown and pull snug but not tight.

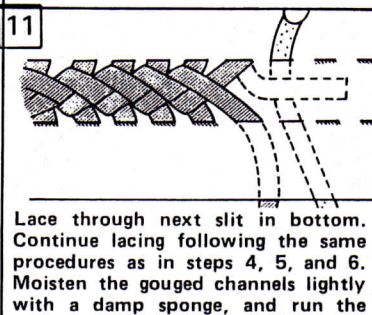

Lace through next slit in bottom. Continue lacing following the same procedures as in steps 4, 5, and 6. Moisten the gouged channels lightly with a damp sponge, and run the stitch tool around the channel on the front side only. This marks position of awl holes to insure even stitches.



To lace corners with the applique stitch, set up parallel rows of slits as shown above, with one slit on the corner of the inside row and four slits on the outside row. It is important to keep the distance between the parallel rows of slits the same going around a corner as they are when lacing in a straight line.

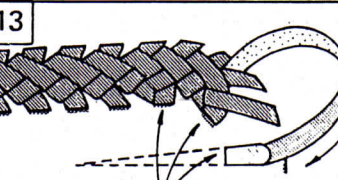

Lace through the three inside corner slits twice each and through the four outside corner slits once each, as shown.

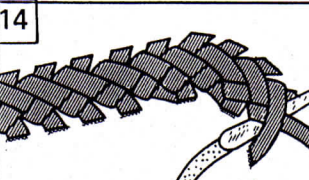

Be sure to go through bight on all corner stitches.

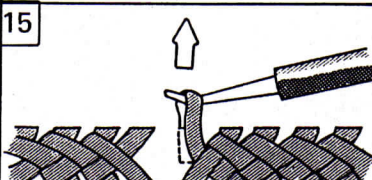

If you are lacing completely around a project, lace to starting point. Use modeling tool to pull end of lace free from first slit as shown.

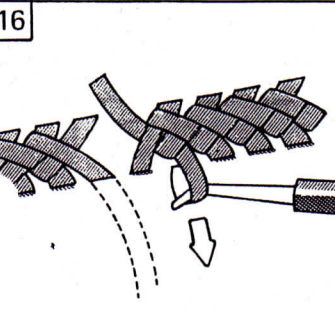

Pull end of lace out of loop.

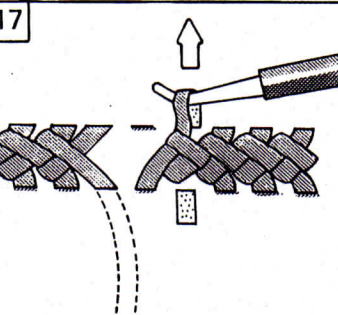

Pull end of lace out of second slit in bottom row and second slit in top.

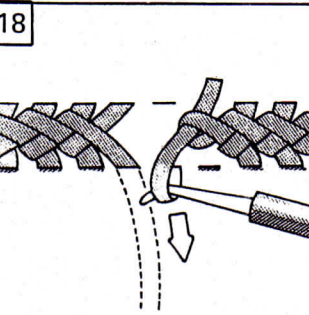

Pull end of lace out of loop. Enlarge loop slightly with modeling tool.

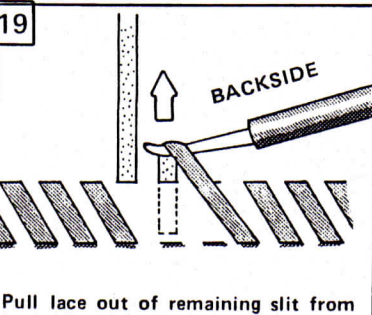

Pull lace out of remaining slit from backside of leather which will leave four empty slits.