

SINGLE LOOP LACING

RECOMMENDED USAGE:

Lightweight leathers or single thickness projects where little lace is required to cover the "raw" edge.

Use 3/32" slits with 3/32" lace.

Single Loop Lacing uses 6½ times more lace than the length of the project. For example; if your project measures 2 ft. around laced part, you will need 13 ft. of lace.

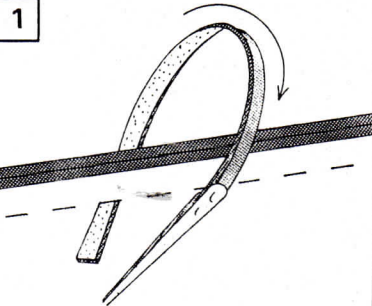

1 Begin at top of project, push lace through front side. Leave about ½" of end.

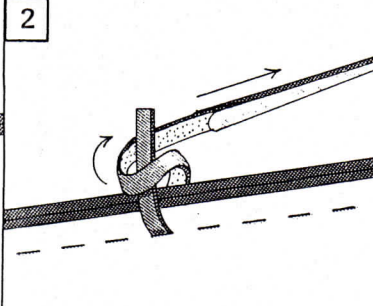

2 Fold end up and loop lace around as shown. Hold with fingers until 1st stitch is tightened.

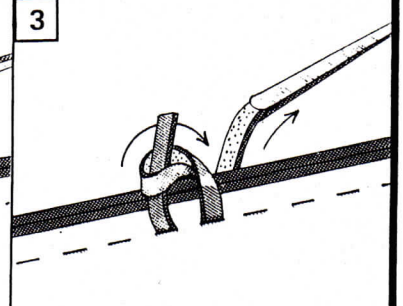

3 Lace through 2nd slit. Be sure smooth side of lace faces you, as shown in drawings. Pull up snugly.

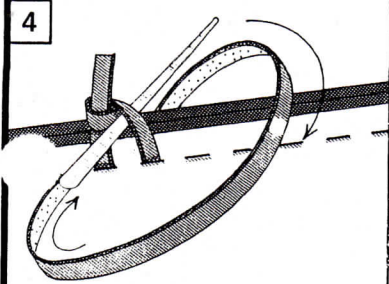

4 Push needle under lace as shown. . . with the flesh side up. Do not twist lace. Pull up snugly.

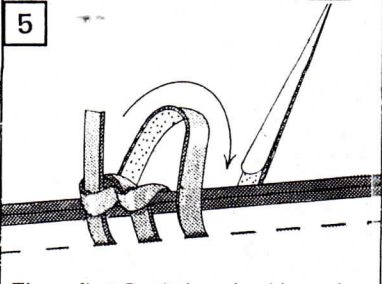

5 These first 2 stitches should not be tight, but snug as they must be adjusted when completing steps 8-16. Continue lacing in this fashion until you reach corner hole.

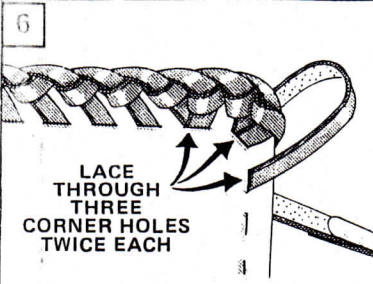

6 LACE THROUGH THREE CORNER HOLES TWICE EACH

Continue lacing as before. When you reach a corner, lace through the three corner holes twice each, as shown.

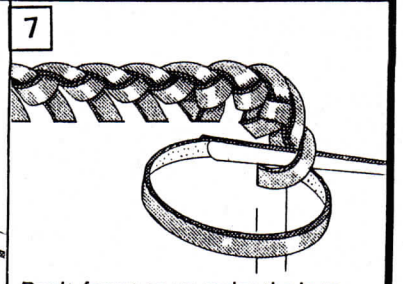

7 Don't forget to go under the loop each time on the corners. Lace to the beginning.

Continued on page 12.

11

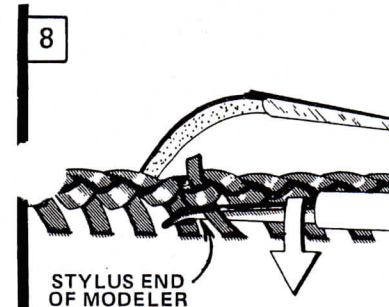

8 STYLUS END OF MODELER

Lace through last slit and under loop. Insert stylus end of modeling tool under end of lace.

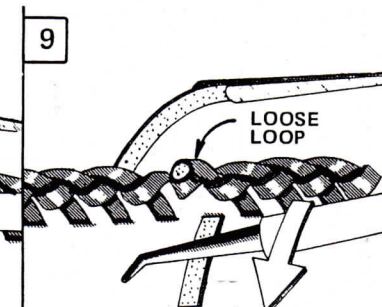

9 LOOSE LOOP

Pull end of lace out of loop with end of modeler as shown. Maintain the loose loop.

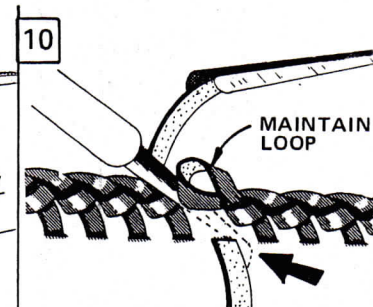

10 MAINTAIN LOOP

Insert stylus between the leathers and hook over the end of the lace as shown above.

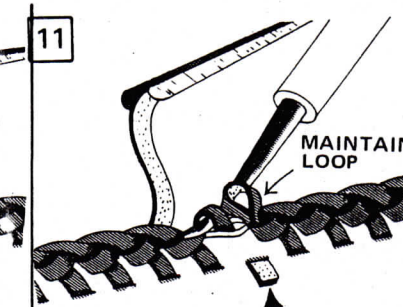

11 MAINTAIN LOOP

Carefully pull up stylus and gradually pull end of lace out of the hole; up between the leathers.

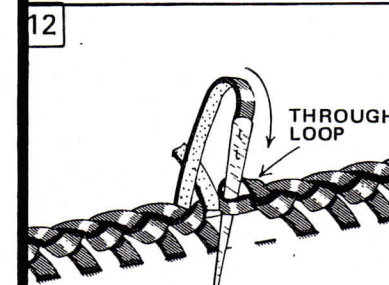

12 THROUGH LOOP

Push needle down through the loose loop, carefully, as shown.

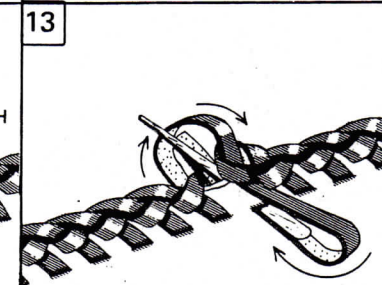

13 Push needle through slit... up between the leathers. Be sure lacing does not twist.

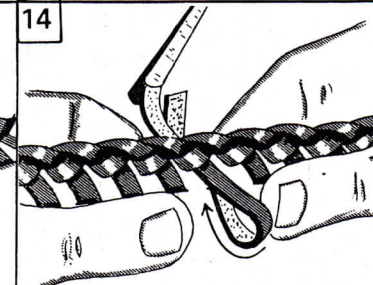

14 Adjust the stitches by pushing and working the lacing together with fingers as shown.

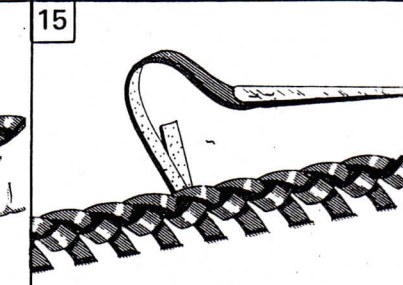

15 Pull lacing up snug and adjust so that all of the stitches appear even.

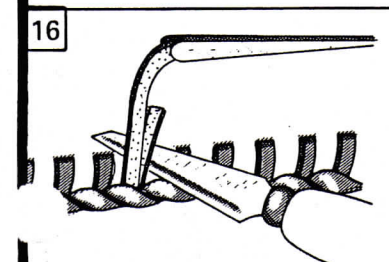

16 Carefully cut off ends from the flesh side, as shown. Tap lacing flat with mallet or roll under a wooden dowel.

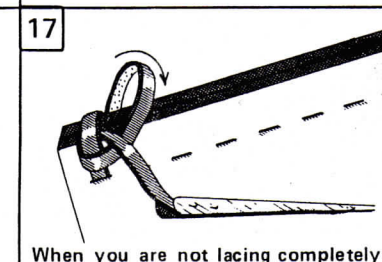

17 When you are not lacing completely around a project you will begin as in Step 9 of the Whipstitch on page 9. Then come under first stitch as shown and continue lacing.

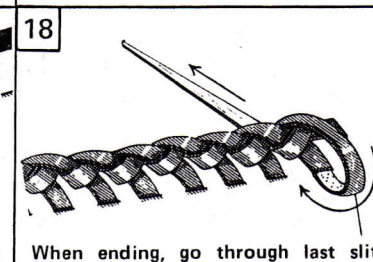

18 When ending, go through last slit, under loop and then go through last slit in front only and come out between the leathers and back a few stitches.

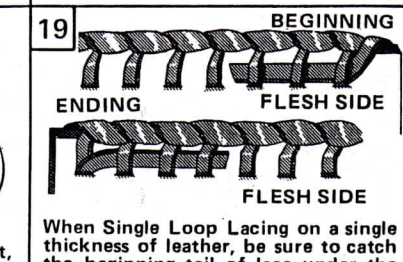

19 BEGINNING ENDING FLESH SIDE FLESH SIDE

When Single Loop Lacing on a single thickness leather, be sure to catch the beginning tail of lace under the first few stitches on the back of the leather. End by running the needle back under the last few stitches on the back of the leather.